

User Manual

A Series A451

Interface Converter

RS-232 ↔ RS-485 Multidrop



The interfacing specialists

A451 User Manual

Version 1.00

April 2000

COPYRIGHTS

All rights reserved. This document may not, in whole or part, be copied, photocopied, reproduced, translated, or reduced to any electronic medium or machine readable form without the express permission in writing from Alfatron Pty Ltd.

Copyright 2000 © Alfatron Pty Ltd

DISCLAIMER

Alfatron Pty Ltd has made every attempt to ensure that the information contained in this document is accurate and complete. Alfatron Pty Ltd makes no representation or warranties of merchantability or fitness for any particular purpose. Alfatron Pty Ltd reserves the right to make changes to this document at any time, without notice. Therefore, Alfatron Pty Ltd assumes no liability for damages incurred directly or indirectly from errors, omissions or discrepancies with the hardware and the manual.

TRADEMARKS

All Company and Product names are trademarks of the Company or Manufacturer respectively.

WARRANTY

Alfatron warrants its products against defects in materials and workmanship for a period of one year from receipt by the customer. All warranty is carried out on a return to depot basis unless an alternative warranty coverage has been arranged.

WARRANTY EXCLUSIONS

The above warranty shall not apply to defects resulting from improper or inadequate maintenance by the customer, unauthorised modifications or misuses, operation outside the environmental specifications for the product, damage due to power surges, lightning strikes or any other phenomenon outside normal operational specifications.

Alfatron Pty Ltd ACN: 005 410 819

P.O. Box 4161

Unit 9/36 New St.

Ringwood VIC 3134

AUSTRALIA

Email: support@alfatron.com.au

Web Site: www.alfatron.com.au



1.0 PRODUCT DESCRIPTION

The A Series A451 is an RS-232 to RS-485 Multidrop interface converter using standard RJ-45 Ethernet cabling on the RS-485 side. On the RS-232 side a DCE/DTE switch is provided for easy reversing of the TD and RD signals.

The RS-485 port will support up to 32 drivers and 32 receivers over a cable length of 1200 metres at speeds up to 115Kbps. Transient Protection is also provided on the RS-485 lines.

Full Duplex (4 wire) or Half Duplex (2 wire) operation may be used on RS-485 and internal jumper settings permit the use of either 'standard' or 'crossed' Ethernet cables. The layout of the A451 is as follows:

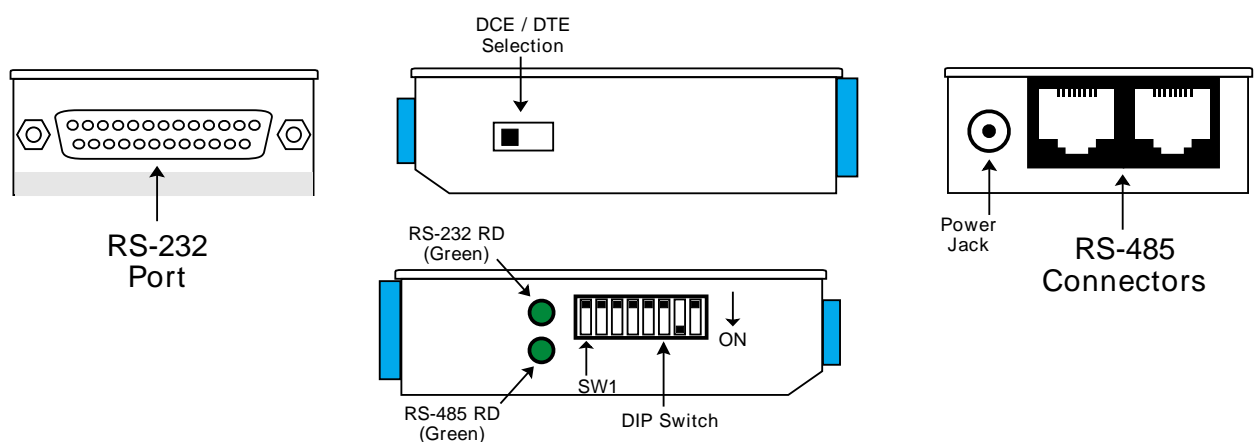

Figure 1 - A451 viewed from all sides

2.0 INSTALLATION

Before installing the A451 please make sure that the DIP Switch settings are according to the requirement of the RS-485 target device. It is also important to select the RS-232 port as either DCE or DTE.

Make sure that all cables are terminated and then insert the power plug into the jack socket and turn the power ON. The A451 is now ready for use.

2.1 LED indicators

The LEDs will operate only if DIP Switch 7 is set to the 'ON' position.

The RD (RS-232) LED indicator will flash each time data is being received by the Serial RS-232 Port. The RD (RS-485) LED indicator will flash each time data is being received by the RS-485 Serial Port.

These LEDs will not operate at any other time.

3.0 INTERFACE APPLICATION NOTES

3.1 About the RS-232 Port

The RS-232 connection is switch selectable as either DTE or DCE. For connection to a standard PC with a straight through serial cable, select DCE.

When operating the A451 without the power adapter it is necessary to connect the CTS/RTS and DTR/DSR signals as the power is drawn from these lines.

In most applications, it is necessary to connect all of the commonly used pins on the RS-232 port (i.e. 1, 2, 3, 4, 5, 6, 7, 8 and 20 on a DB25 interface).

3.2 About the RS-485 Port

The RS-485 port may be configured for either a 4-wire or a 2-wire network. This is done simply by choosing the appropriate jumper setting on the connector JP1 located behind the RJ-45 sockets, as follows:

Pin	Description of Signal
1	Transmit Data Plus (TD+)
2	Transmit Data Minus (TD-)
3	Receive Data Plus (RD+)
4	-
5	-
6	Receive Data Minus (RD-)
7	Ground
8	Ground

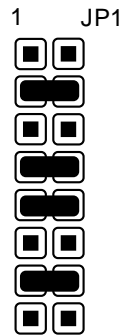

Standard 4-wire
(Factory Default)

Pin	Description of Signal
1	Receive Data Plus (RD+)
2	Receive Data Minus (RD-)
3	Transmit Data Plus (TD+)
4	-
5	-
6	Transmit Data Minus (TD-)
7	Ground
8	Ground

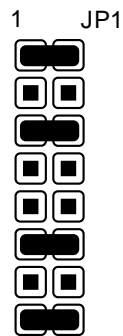

Crossed 4-wire
Configuration

Pin	Description of Signal
1	(RD+) and (TD+)
2	(RD-) and (TD-)
3	-
4	-
5	-
6	-
7	Ground
8	Ground

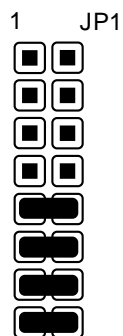

2-wire
Configuration

3.3 Other RS-485 Considerations

When installing an RS-485 2-wire network the RS-485 transmitter must be controlled by the RS-232 serial device. This transmitter may be controlled by either the RTS/CTS or DTR/DSR signals.

If the RS-232 side is using software to control devices then it may require a local echo of what it transmits, if so, turn DIP Switch 6 to the 'OFF' position.

If the distance of the RS-485 device is less than 100metres then it is not necessary to terminate the RS-485 bus.

3.4 Using A451s as RS-232 Line Extenders

A pair of A451s may be used to extend the distance at which RS-232 data is transmitted. The A451s are connected via their RS-485 ports to take advantage of the greater data transfer distances achievable with RS-485.

The following examples show how to connect two A451s together via their RS-485 ports using various cable types. Note that the internal jumper JP1 must be set as per these diagrams.

Example 1: Using a Standard RJ-45 Ethernet Cable

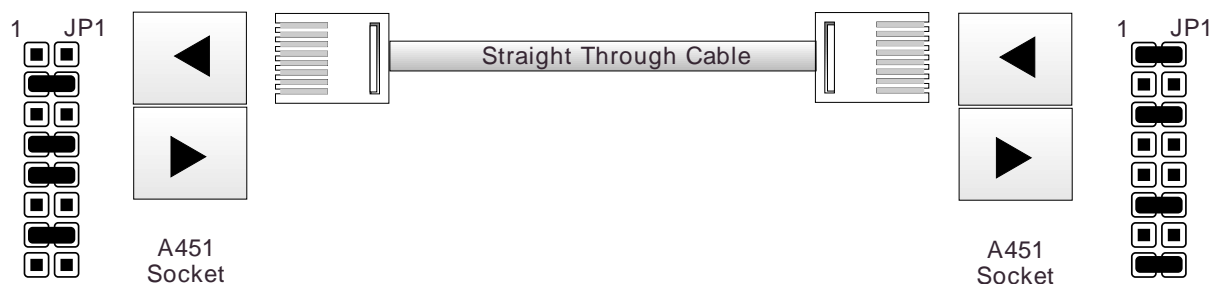

Example 2: Using a Crossed RJ-45 Ethernet Cable

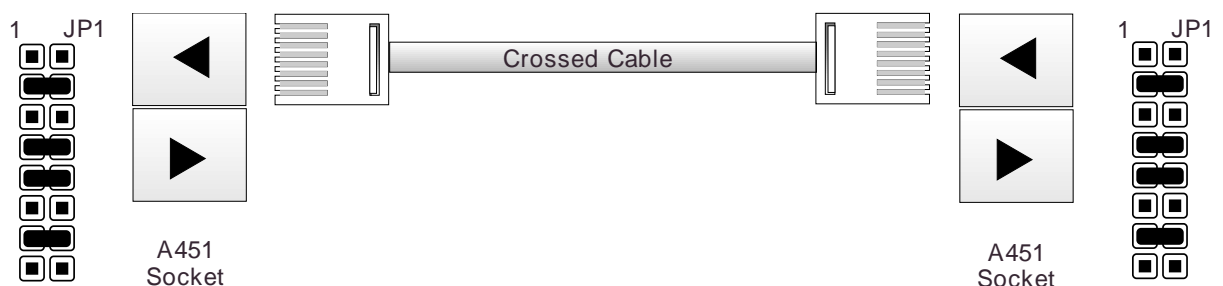

Note: Using a Crossed Cable requires no changes to the Factory Set JP1

4.0 CONFIGURATION OF THE RS-485 PORT

4.1 RS-485 DIP Switch Settings

DIP Switch					Function
1	2	3	4	5	
on	off	off	off	off	RS485 transmitter Enabled when DTR/DSR is High
off	on	off	off	off	RS485 transmitter Enabled when RTS/CTS is High
off	off	off	off	off	RS485 transmitter ALWAYS Enabled
off	off	on	off	off	RS485 transmitter NEVER Enabled
off	off	on	on	on	Monitor Mode

DIP Switch	Setting	Function
6	OFF	RS485 receiver always enabled (local echo for 2-wire RS485)
	ON	RS485 receiver enabled only when RS485 transmitter disabled
7	OFF	LEDs always OFF. Saves power in 'non powered' operation
	ON	LEDs indicate RD/TD Data Flow
8	OFF	No termination on RS485 receiver
	ON	120ohm termination on RS485 receiver

4.2 Factory Default RS-485 DIP Switch Settings

- RS-485 Transmitter ALWAYS enabled
- RS-485 Receiver ALWAYS enabled (local echo for 2-wire RS-485)
- LEDs indicate RD/TD Data Flow
- No Termination on RS-485 Receiver

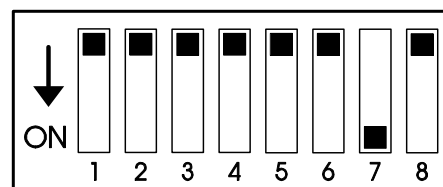

5.0 INTERFACE PORT PIN ASSIGNMENTS

5.1 RS-232 Serial Port Pinout

<u>Pin</u>	<u>Status</u>	<u>Set for DCE</u>	<u>Set for DTE</u>
1	Used	Frame Ground	Frame Ground
2	Input / Output	RD	TD
3	Output / Input	TD	RD
4	Linked to Pin 5	CTS	RTS
5	Linked to Pin 4	RTS	CTS
6	Linked to Pin 20	DTR	DSR
7	Used	Signal Ground	Signal Ground
8	Not used-Pulled High 4K7	DCD	DCD
20	Linked to Pin 6	DSR	DTR

Note: Pins 4, 5, 6, 8 and 20 are pulled to the correct levels to allow a PC serial port to operate under most conditions without any additional loopback connections.

5.2 Factory Default DCE/DTE Switch Setting

The Factory Default for the RS-232 Port is DCE.

DCE < > DTE



5.3 RS-485 Serial Port Pinout

Pin number 1 for each RJ-45 connector is shown here in the diagram. The two RJ-45 connectors are identical in pin assignment and are connected in parallel.

The signals associated with each pin depend on the configuration of the jumper JP1. Please refer to Section 3.2 for these details.

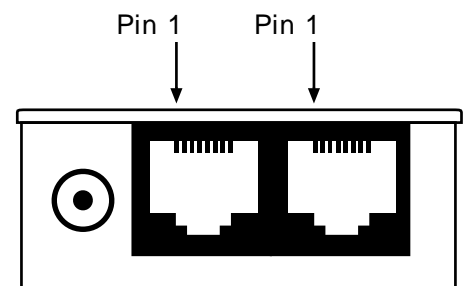

5.4 Factory Default JP1 Jumper Setting

The A451 is shipped with JP1 set to Standard 4-wire configuration as shown here:

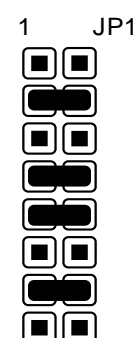

Standard 4-wire
(Factory Default)

6.0 CABLE GROUNDING

Alfatron recommends the use of shielded cable with all of its products. Shielding reduces EMI Radiation and improves noise immunity. This helps minimise interference to other equipment and will improve communications reliability.

6.1 RS-232 Cable Construction

The recommended cable construction is as follows:

- Take the shield (surrounding cable wires) and solder it to the Frame Ground (FG) pin. If FG is not available, use Signal Ground (SG) but in this case always use a separate wire for ground which is connected at both ends.
- The shield must be connected at both ends of the cable.

6.2 RS-485 Cable Construction

While the RS-485 differential signal does not require a ground signal for communication, we recommend that a ground wire is always connected in an RS-485 Multidrop Network.

The longer distances available with RS-485 can present significant differences in the voltage levels of the 'Ground' signal. This can lead to loss of data and at the extreme, cause damage to the equipment.

7.0 CABLE EXAMPLES

7.1 RS-485 Cable from A451 to User Device

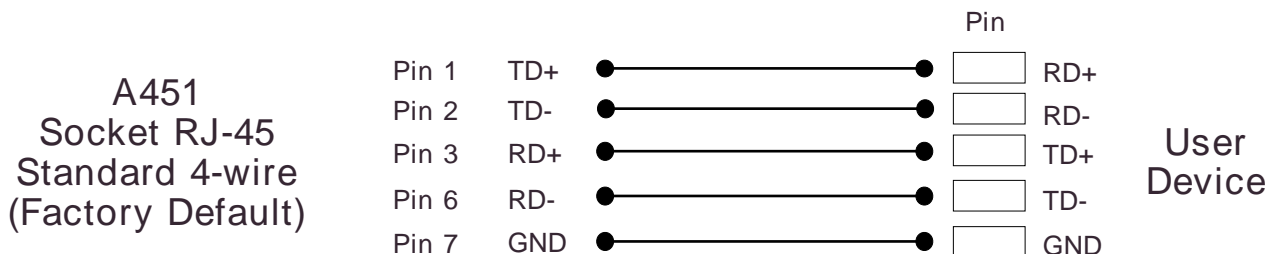

7.2 RS-232 Connection to a PC with a DB-25 Serial Connector

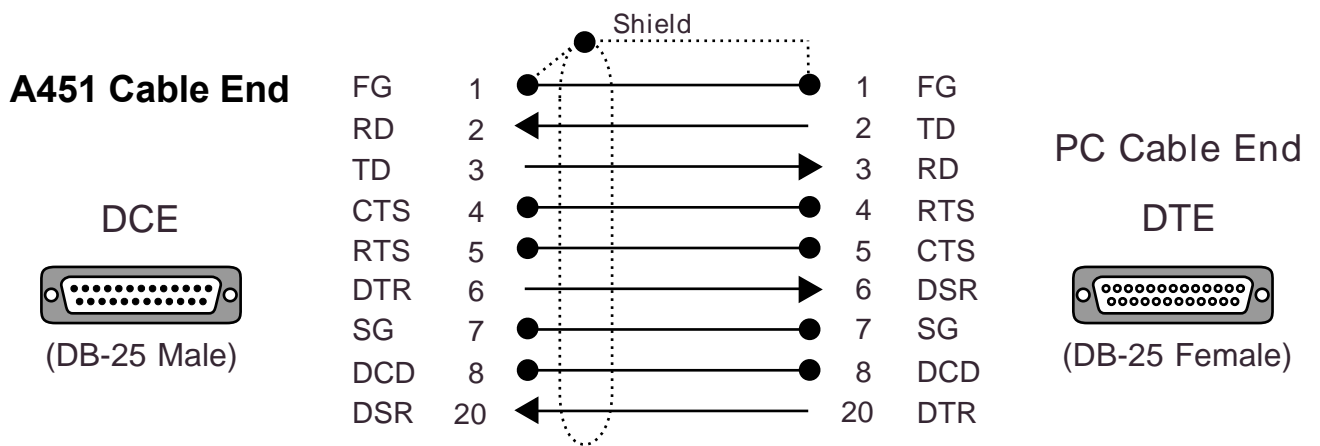

7.3 RS-232 Connection to a PC with a DB-9 Serial Connector

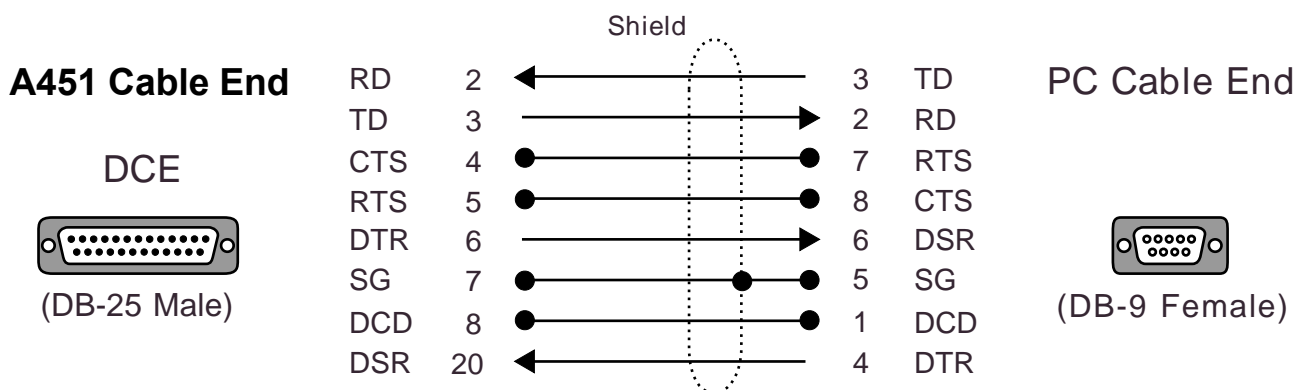

7.4 RS-232 Cable for Other Devices

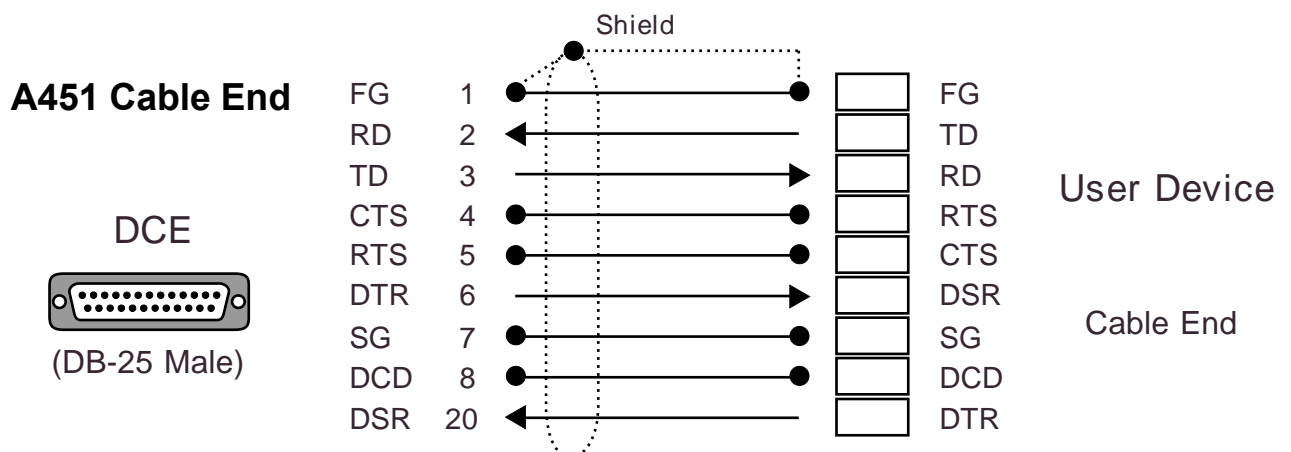

8.0 SPECIFICATIONS

RS-232C Port: Asynchronous RS-232C/V.24
Select as DCE or DTE
DB-25 female connector
Speed capability dependant on cable length up to 64k bits per second

RS-485 Port: RS-485
Two RJ-45 connectors for multidrop setup
Switchable 120ohm Termination for RD line

LED Indicators: Receive Data - RS-232 (Green)
Receive Data - RS-485 (Green)

Power Supply: 9V (200mA) DC Power Adapter
Reverse polarity protection
Plug jack - 5.5mm outer/2.5mm inner diameter
Polarity is Outer Negative 

Dimensions: 84mm x 58mm x 23mm

Weight: 160 grams

Operating Temperature: 10° to 35° C

Stroage Temperature: 0° to 45° C

All specifications subject to change without notice



N42



DECLARATION OF CONFORMITY

according to the European Commissions EMC Directive 89/336/EEC

We, Name of Manufacturer: ALFATRON PTY. LTD
of, Address of Manufacturer: UNIT 9, 36 NEW ST.
RINGWOOD VIC 3134
AUSTRALIA

Australian Company Number: ACN: 005 410 819

declare under sole responsibility that the product:

Product Name: A Series RS-232 < > RS-485
Interface Converter

Model Number: A451

to which this declaration relates is in conformity with the following standards:

CISPR-22 / EN 55022 class B	EMI from Information Technology Equipment (ITE)
IEC 801-2 / prEN55024-2	Electro Static Discharge Immunity
IEC 801-3 / prEN55024-3	Radiated RF Immunity
IEC 801-4 / prEN55024-4	Electrical Fast Transients Immunity